

# DHI-SSD-C800A

## 2.5" SATA Solid State Drive



- Adopts high-quality wafer level chip
- Supports SATA III protocol with transmission speed up to 550 MB/s
- View information through S.M.A.R.T
- Provides better read and write performance with TRIM and NCQ
- Low power consumption management

### System Overview

As a new generation of 2.5" SSD product launched by Dahua, DHI-SSD-C800A series adopts high-quality 3D wafer level chip and high-performance controller. It is consumer-grade solid state drive designed for personal desktops and notebooks. The product can process data efficiently and ensure quick start-ups. In multi-tasking, it can ensure high speed and stability.

### Scene

DHI-SSD-C800A series is standard 2.5" consumer-grade solid state drive which is applicable to personal desktops, notebooks, all-in-one computers, and more.

### Technical Specification

Product Model	DHI-SSD-C800AS128G	DHI-SSD-C800AS256G	DHI-SSD-C800AS512G
Capacity <sup>1</sup>	128 GB	256 GB	512 GB
Form Factor	2.5"		
Port	6 Gb/s SATA		
Net Weight	Max 40 g (0.09 lb)		
Product Dimensions	100.20 mm × 69.90 mm × 7.00 mm (3.94" × 2.75" × 0.28")		
Packaging Dimensions	140.50 mm × 105.50 mm × 15.50 mm (5.53" × 4.15" × 0.61")		
Memory Component	3D TLC	3D TLC	3D TLC
Power Consumption <sup>2</sup>	1065 mW (max) 400 mW (idle)	1186 mW (max) 412 mW (idle)	1300 mW (max) 415 mW (idle)
S.M.A.R.T	Support		
TRIM	Support		
Garbage Collection	Support		
Sequential Read <sup>2</sup>	Up to 550 MB/s	Up to 550 MB/s	Up to 550 MB/s
Sequential Write <sup>2</sup>	Up to 460 MB/s	Up to 460 MB/s	Up to 490 MB/s
4K Random Read <sup>2</sup>	Up to 50000	Up to 50000	Up to 52000
4K Random Write <sup>2</sup>	Up to 57000	Up to 57000	Up to 58000
MTBF	1,500,000 hours		
Operating Temperature	0°C to +70°C (+32°F to +158°F)		
Storage Temperature	-40°C to +85°C (-40°F to +185°F)		

Operating Humidity	5%–95% (non-condensing)		
Vibration Resistance	10–1000 Hz, 2.78G		
Shock Resistance	1500G/0.5 ms (half sine wave)		
TBW	64 TB	128 TB	256 TB
Warranty <sup>3</sup>	3-year limited warranty		
Reference Information	<ol style="list-style-type: none"> <li>Capacity calculation: 1GB = 1 billion bytes (IDEMA). Actual available capacity might be reduced (due to formatting, partition, operating system applications, or other necessary usage).</li> <li>System configuration of performance test: Intel Z390 Chipset, Intel Core i9-9900KF@3.6GHz, 16GB DDR4; operating system-Windows 10 x64; testing tool-CrystalDiskMark 6.0.0.</li> <li>Warranty period or maximum write amount (TBW), whichever comes first.</li> <li>High performance SLC cache has been enabled.</li> </ol>		

## Dimensions (mm[inch])

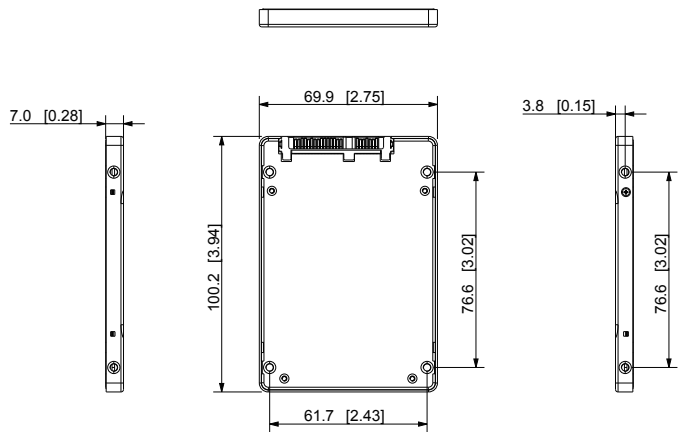

## Ordering Information

Type	Model	Description
Memory Card	DHI-SSD-C800AS128G	2.5" SATA Solid State Drive DHI-SSD-C800AS128G
	DHI-SSD-C800AS256G	2.5" SATA Solid State Drive DHI-SSD-C800AS256G
	DHI-SSD-C800AS512G	2.5" SATA Solid State Drive DHI-SSD-C800AS512G

## Installation

Install by Cable Connection

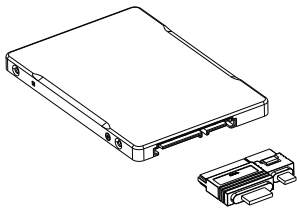

Install by Direct Insertion

